

- CV** Check Valves
- SH** Shuttle Valves
- LM** Load/Motor Controls
- FC** Flow Controls
- PC** Pressure Controls
- LE** Logic Elements
- DC** Directional Controls
- MV** Manual Valves
- SV** Solenoid Valves
- PV** Proportional Valves
- CE** Coils & Electronics
- CB** Cartridge Bodies
- BC** Bodies & Cavities
- TD** Technical Data

**Valve/Cavity Compatibility**

For additional information see Technical Tips on pages BC1-BC2.

CAVITY	VALVE				
	Winner's Circle	Parker	Waterman	FPS	CEC
Winner's Circle	X	X	X	X	X
Parker	X	X	X		
Waterman	X	X	X		
FPS	X			X	X
CEC	X			X	X

**Performance Curve**  
**Pressure Drop vs. Flow**

**Dimensions** Millimeters (Inches)

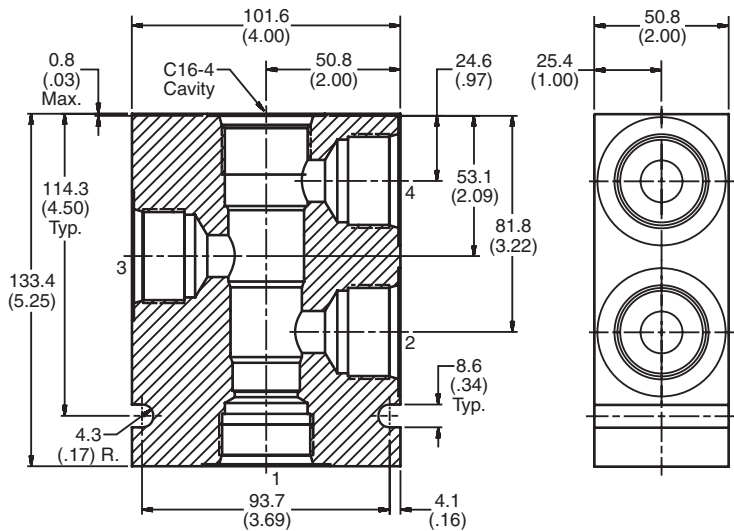
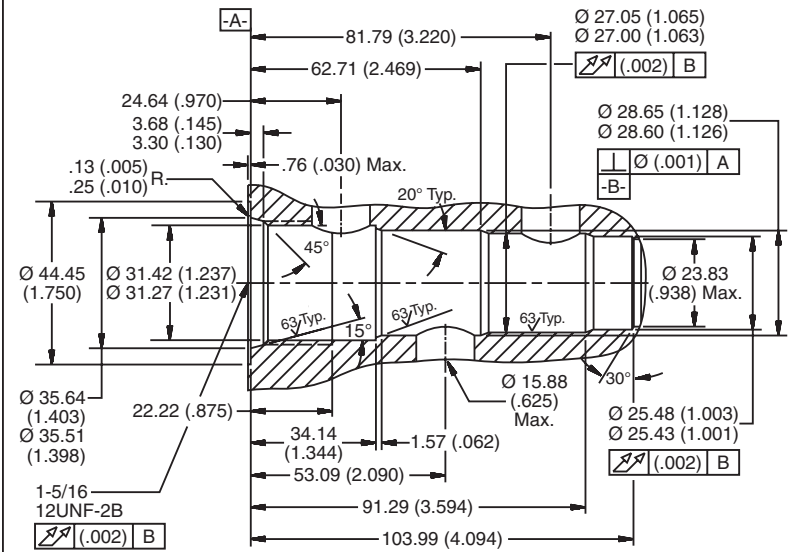

**Ordering Information**

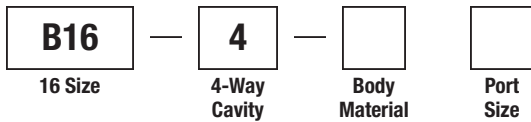

Code	Body Material
Omit	Steel
A	Aluminum

Code	Port Size
16T	SAE - 16

**Form Tool:** Rougher NFT16-4R  
 Finisher NFT16-4F  
**Weight:** 3.75 kg (8.125 lbs.)